

STRENGTH 9000 SERIES TRAINING EQUIPMENT

SU10 Incline Chest Press

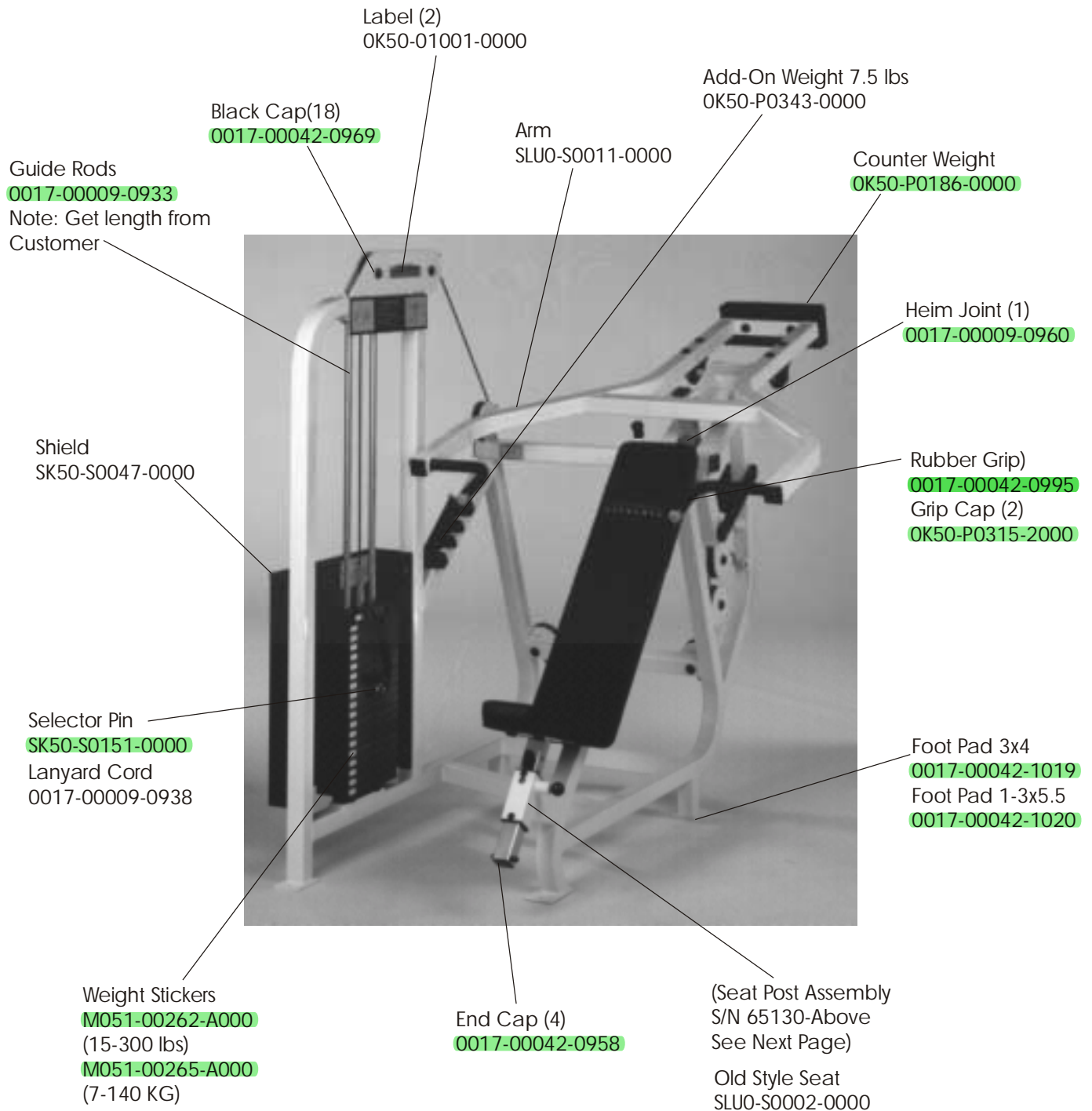

STRENGTH 9000 SERIES TRAINING EQUIPMENT

SU10 Incline Chest Press

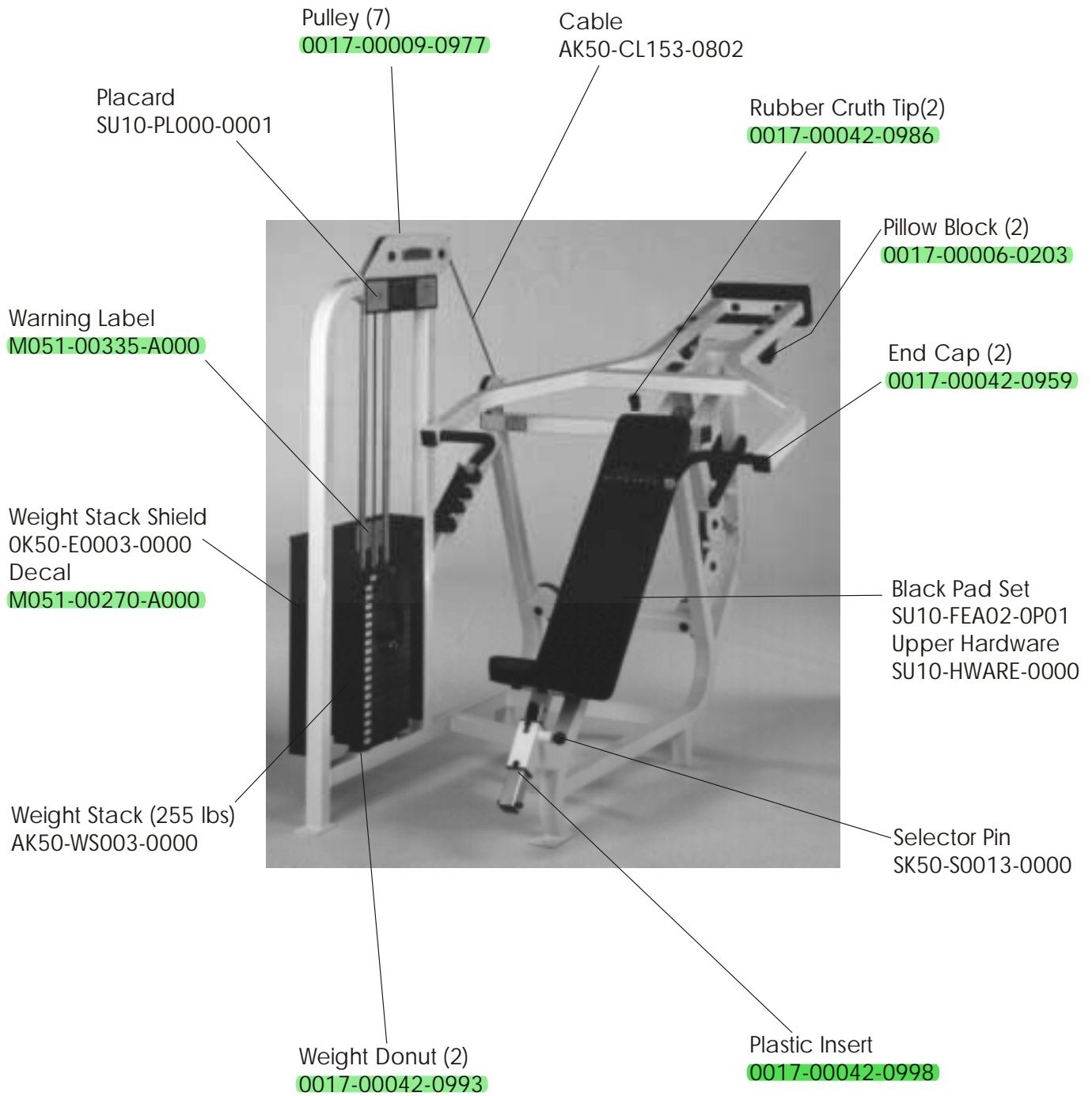

STRENGTH 9000 SERIES TRAINING EQUIPMENT

SU10 Incline Chest Press

Thick Nylon Washer
0017-00104-0349
Bolt 2-1/2"
0017-00101-1417
Large Teflon Bushing
0017-00009-1027

Bushing
FB31-M0045-0000

Bolt
0017-00101-1431



Nylon Washer
0017-00104-0373

Stop
SU10-S0008-0000

Linkage
OK50-P0424-0000

HEIM Joint Assembly

HEIM Joint	Washer, Small
0017-00009-0960	0017-00104-0359
Jam Nut	Washer, Large
0017-00108-0240	0017-00104-0352
Shoulder Bolt	Nut 5/16"
0017-00101-1409	0017-00103-0232
Nylon Washer	
0017-00104-0349	

Pulley Plate
OK50-P0125-0000

STRENGTH 9000 SERIES TRAINING EQUIPMENT

SU10 Incline Chest Press



STRENGTH 9000 SERIES TRAINING EQUIPMENT

SU10 Seat Post Assembly - S/N 65130-Above

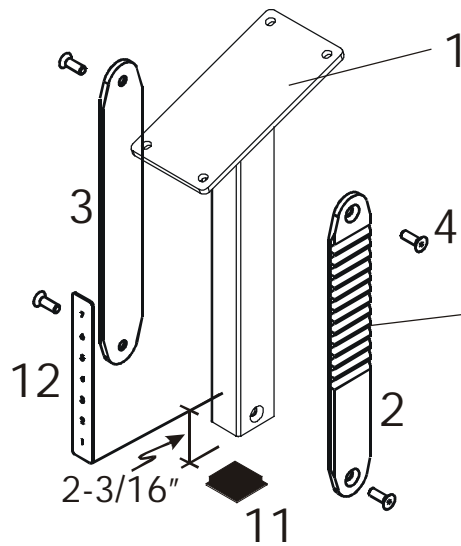

The 13 notch front/back striker plate is grey. The 14 notch front/back striker plate is black and was implemented first quarter 2001. Notched striker plate to be installed on seat post such that it is on the same side as the lever handle.

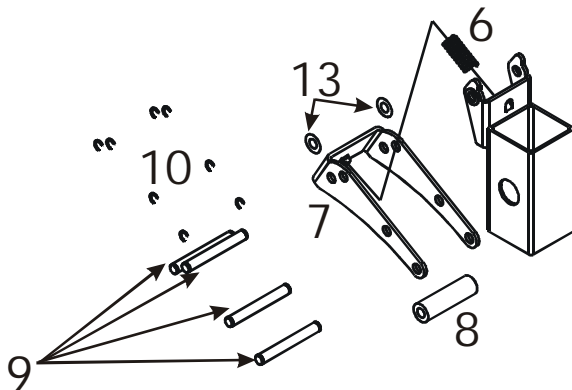

NOTE: The Seat Guide is welded to the frame. Shown separately for illustration purposes only.

BILL OF MATERIALS			
Item No.	Qty.	Part Number	Description
1	1	AK50-S0028-0000	Seat post assembly
2	1	OK50-P0547-0000	Front striker plate (14 notch)
3	1	OK50-P0548-0000	Back striker plate
4	4	0017-00101-1655	5/16" x 24 flat bolt
6	1	0017-00009-1079	Spring
7	1	OK50-P0550-0000	Lever release
8	1	0017-00042-1089	Rubber grip
9	4	OK50-P0551-0000	Grooved pin
10	8	0017-00100-0190	Retaining clips
11	1	0017-00042-0944	1-1/2" x 1-1/2" End cap
12	1	M051-00363-A000	Number strip
13	2	0017-00104-0373	Nylon washer